

Safe Work at the Band Saw

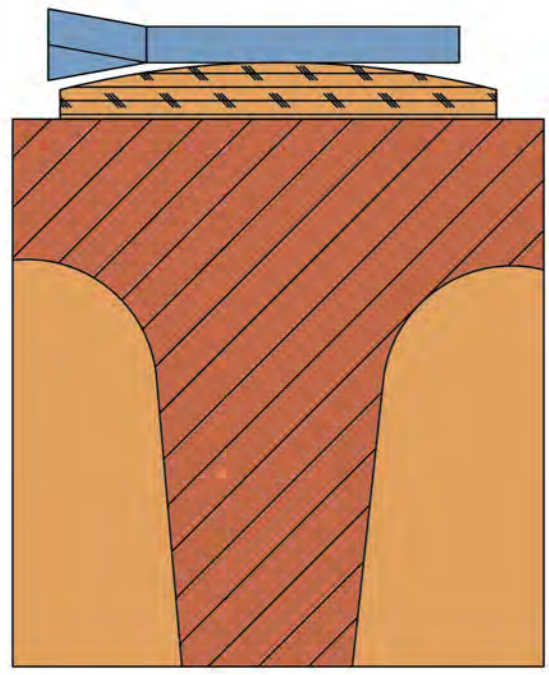

Correct position of the saw blade on the drive wheels.

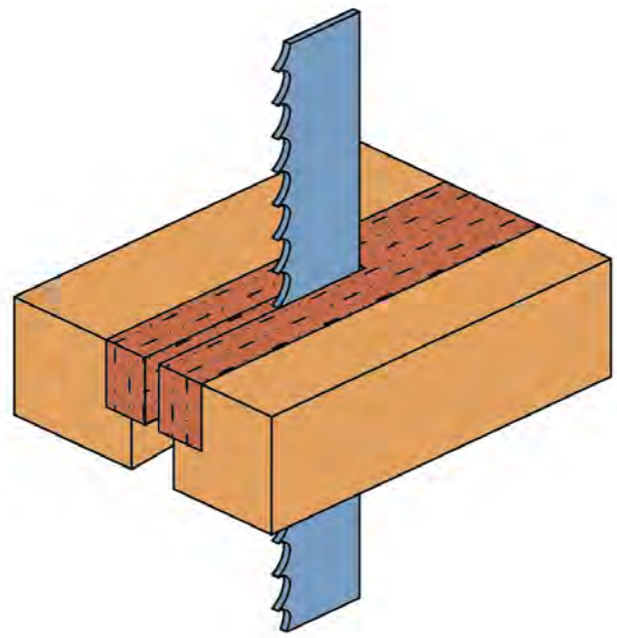

The table insert should be flush with the table, cuttable, replaceable and narrow to the blade

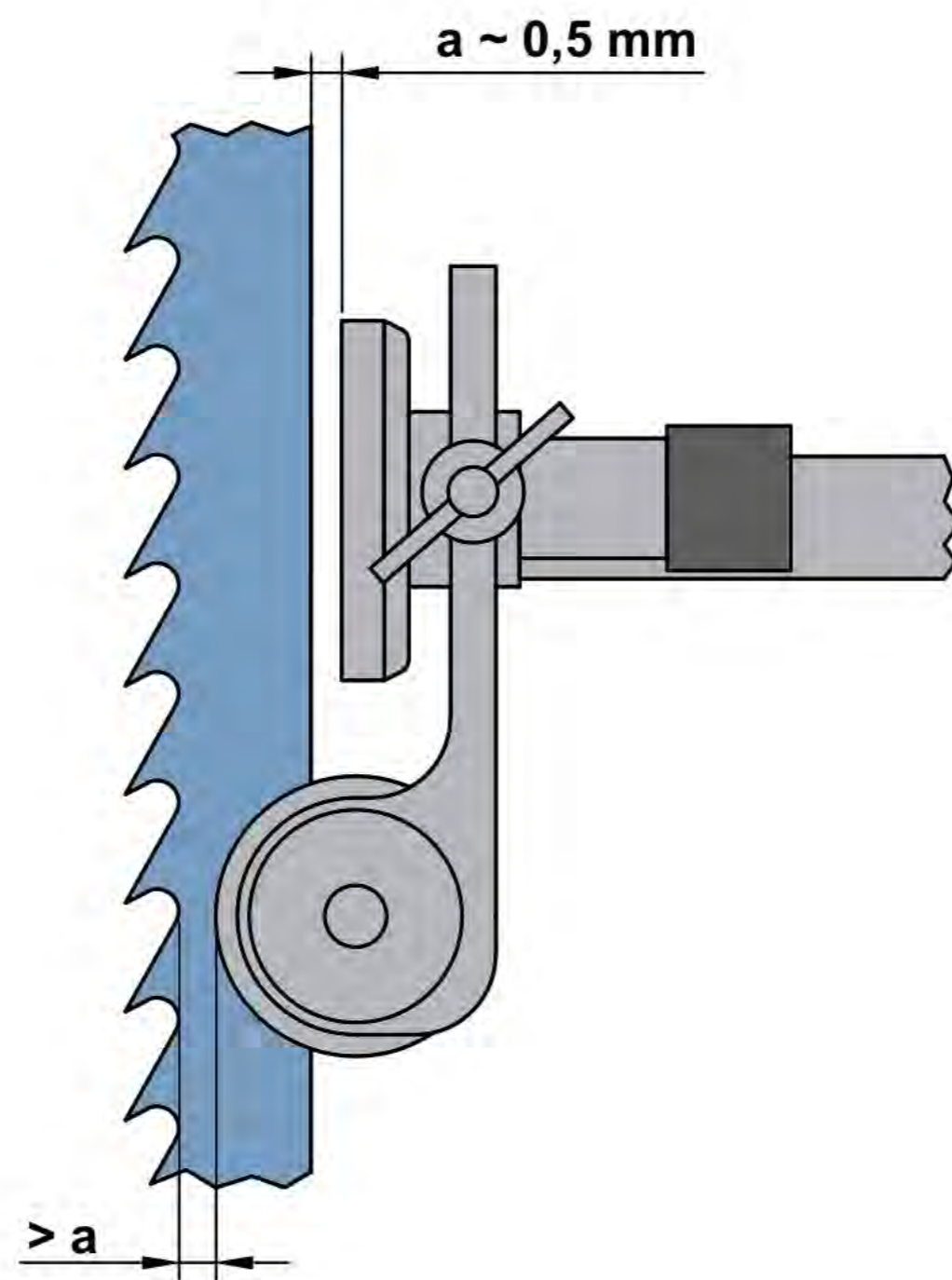

Adjustment of the saw blade guides.

General information

- Turn off the machine before cleaning and maintenance. Make sure, that it will not start accidentally.
- Operators must be physically fit.
- Operators need to be instructed before using the machine.
- Wear tight clothes, safety shoes and ear protection.
- Use of Goggles is optional
- Before you leave the machine, turn it off, stop the saw blade with the engine break and secure the saw blade against touching if necessary.

Tools

- Only use steady inclined and sharp saw blades.
- Thickness of the saw blade: 1/1000 of the drive wheel diameter
- Use narrow saw blades only for curve cutting.

Adjustment

- Adjust the setting of the saw blade by changing the inclination of the upper drive wheel. Use the incline adjustment while the upper and lower saw guides are pushed back. While adjusting turn the drive wheels only by hand.
- Adjustment of the saw guides: Saw guides at the side near to the tooth ground, saw guide at the back should have a tiny distance to the blade, so it will only move if the saw blade is under force.
- All covers and safety equipment must be closed.
- Adjust the upper saw guide just above the thickness of the workpiece.
- Use a table extension for bigger pieces.

Operation

- At the feed motion put your hands with closed fingers flat on the workpiece.
- Use the push stick in the danger zone, also for waste pieces. Replace broken push sticks.
- Use the machine only with dust extraction.
- Use the machine according to the operating instructions.
- Remove waste pieces to keep the workspace clean and avoid stumbling.



Rip cutting of upright pieces with fence and push block



Cross cutting of upended pieces using the machine stand and a square as support

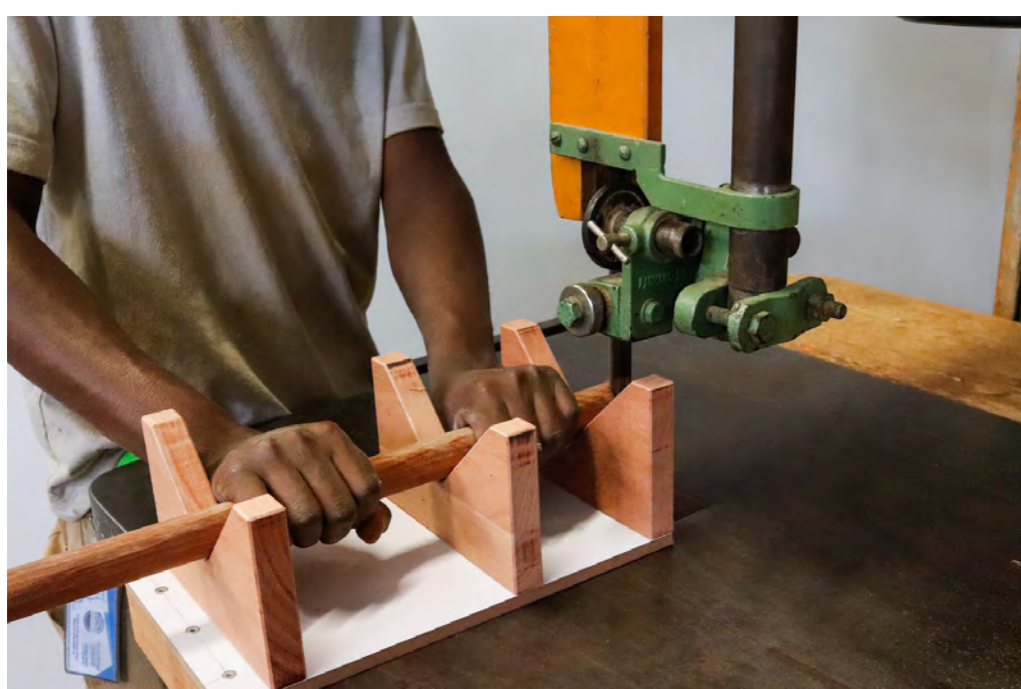

Cross cutting of round pieces with a jig.



Hand position while cutting curves.



Device and hand position for cutting round panels.

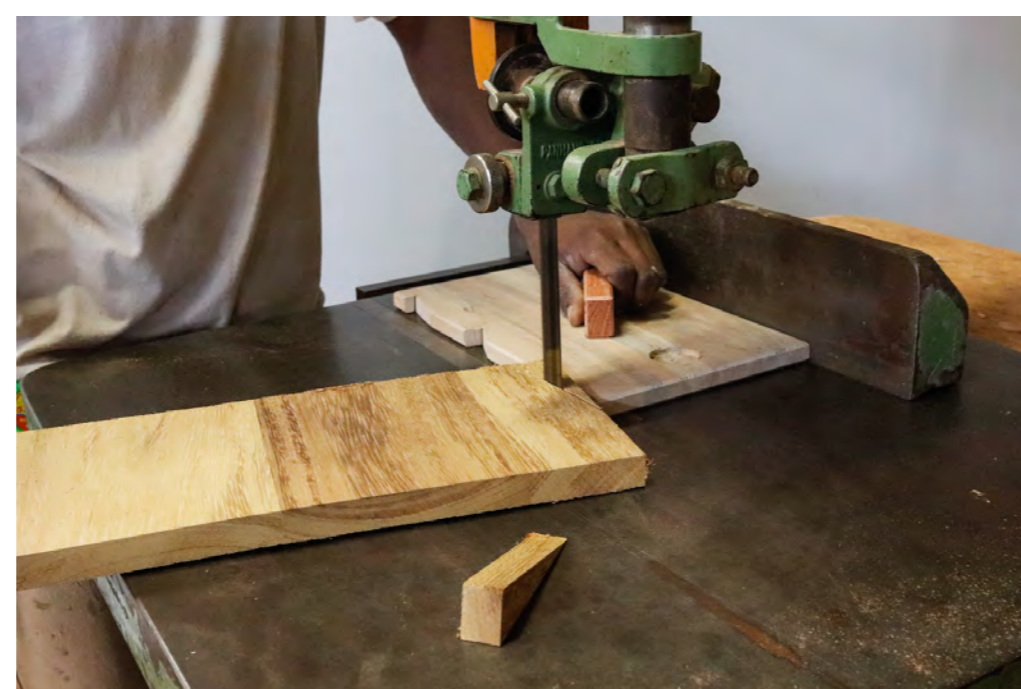

Cutting of cutter pins with a Jig.

Electrical installation & repair of machines should always be done by a professional electrician, to avoid accidents and prevent fire!



proWOOD
promoting competence
in wood technology

Supported by



Invest for Jobs
Opportunities for Growth in Africa

On behalf of



Federal Ministry
for Economic Cooperation
and Development

Implemented by



sequa **IB**